

## 高数值孔径宽谱段折反射式物镜设计

王超<sup>1,2</sup>, 曲贺盟<sup>1,2\*</sup>, 管海军<sup>1,2\*\*</sup>, 王哈<sup>1</sup>, 张继真<sup>1,2</sup>, 谢晓麟<sup>1,2</sup>, 王宁<sup>1</sup><sup>1</sup>长春光智欧科技有限公司, 吉林 长春 130102;<sup>2</sup>中国科学院长春光学精密机械与物理研究所, 吉林 长春 130033

**摘要** 针对基因测序、半导体检测、工业显微镜及生命医疗等领域对显微物镜日益增长的技术需求,成像谱段向着宽谱段深紫外(DUV)方向发展,目前非浸液式显微物镜存在数值孔径(NA)低、视场小、宽谱段内色差严重等问题。基于此,提出一款折反射式物镜。所提折反射式物镜具有宽谱段、高数值孔径、消色差等优点,根据折反射式结构的消色差光学特性,镜片只采用一种材料就可以校正色差。系统由12片镜片组成,数值孔径为0.91,成像谱段为深紫外到可见光(275~600 nm),最大视场为0.3 mm,系统全视场全谱段波像差小于0.033 $\lambda$ ,消除了二级光谱,成像质量满足使用要求。

**关键词** 高数值孔径; 深紫外; 折反射物镜; 消色差

中图分类号 O435 文献标志码 A

DOI: 10.3788/AOS230689

## 1 引言

随着国家基因测序领域、半导体芯片领域及生命医疗领域的快速发展,对显微光学系统的需求也逐渐提高,提出了高数值孔径(NA)、大视场、宽谱段的技术要求。物镜作为显微光学系统的核心组成部分,关乎着整个系统的成像性能<sup>[1-2]</sup>,针对目前的需求,物镜的成像谱段从可见光谱段逐步延伸到深紫外(DUV)谱段,数值孔径也在逐步增大。当成像物体位于空气中时,非浸液式物镜数值孔径存在理论极限,提高系统数值孔径需要高折射率的浸没液体。2015年,薛金来等<sup>[3]</sup>设计了一款平场复消色差显微物镜,其数值孔径为0.75,谱段为400~760 nm,系统采用全透射式结构,畸变小于2%,实现了可见光波段内的复消色差。为了解决宽谱段内消色差的问题,还可以采用折反射式镜组结构。美国一项专利<sup>[4]</sup>采用这一结构形式,系统采用浸没式,数值孔径为1.2,视场为0.15 mm。2018年,长春光学精密机械与物理研究所张新<sup>[5]</sup>设计了一款浸液式显微物镜,在320~800 nm范围内,数值孔径为1.0,系统采用折反射式结构,液体介质为水或生物浸液,镜片采用球面和非球面。在基因测序领域内,浸液式显微物镜虽然可以提升数值孔径、增大检测通量,但是受限于生物样本特性,液体介质会对检测产生一定的影响。因此,非浸液式高数值孔径物镜成为国内外科研学者亟须解决的技术难题。目前,传统非

浸液式高数值孔径商用显微物镜,如蔡司NA0.9物镜,成像谱段为400~700 nm,视场一般在0.1 mm左右,难以满足高数值孔径、宽谱段的高端物镜需求<sup>[6]</sup>。

在基因测序领域内,高通量显微成像是检测生物信息最主要的工具,其中,高通量显微物镜是目前需要攻克的技术难题。对于光学从业者而言,提高检测通量的方式通常有提高系统数值孔径和增大视场两种,浸液式物镜数值孔径的提升与液体折射率等物理特性相关。本文针对非浸液式显微物镜展开研究,围绕着高通量显微物镜的技术需求和发展趋势,设计了一款高数值孔径、宽谱段的新型折反射式物镜,针对高数值孔径、大视场、消色差等技术指标,通过计算位置色差,证明折反射式物镜能够采用同种材料实现宽谱段位置色差校正。根据像差计算公式,进行光焦度分配,得到光学系统的初始结构,利用光学设计软件ZEMAX优化并评价物镜成像质量。结果表明,所设计物镜在宽谱段范围内成像质量优异,实现了高数值孔径、宽谱段物镜复消色差。

## 2 宽谱段折反射物镜校正色差

光线入射介质的折射率随波长谱段的不同而变化,波长越短折射率越大。当自然光通过一片正透镜时,由于红光折射率较小,波长较长的红光焦点会更加远离正透镜。轴上两种颜色的光成像位置的差异就是位置色差,即轴向色差<sup>[7]</sup>,如图1所示。通常为了校正

收稿日期: 2023-03-17; 修回日期: 2023-04-17; 录用日期: 2023-05-05; 网络首发日期: 2023-05-15

基金项目: 吉林省科技发展计划青年成长科技计划项目(20210508036RQ)、吉林省科技发展计划重点研发项目(20210201090GX)

通信作者: \*quhemeng@x126.com; \*\*navy.2.14@163.com

轴向色差,需要一组不同材料的正负透镜组合。根据密接薄透镜系统消色差条件,两片光学元件需满足以下公式:

$$\frac{\phi_1}{v_1} + \frac{\phi_2}{v_2} = 0, \quad (1)$$

$$\phi_1 + \phi_2 = 0, \quad (2)$$

式中: $\phi$ 为光学透镜的光焦度; $v$ 为光学透镜的阿贝数,表示透镜色散能力。由消色差条件可知,两片透镜阿贝数相差越大、光焦度相差越小时,系统可以很好地校正色差。如果想进一步校正二级光谱,需要两片透镜材料的色散系数相近且阿贝数相差较大,但是对于常规光学材料而言,两片式透镜组合不能完全消除残余的二级光谱,只能选用特殊光学材料或者折反射式元件,无论选用哪种方式,都极大增加了成本。对于 DUV 波段而言,常用的玻璃材料较少,很难实现不同镜片阿贝数搭配消色差<sup>[8]</sup>。



图 1 正透镜位置色差

Fig. 1 Chromatic aberration of positive lens position

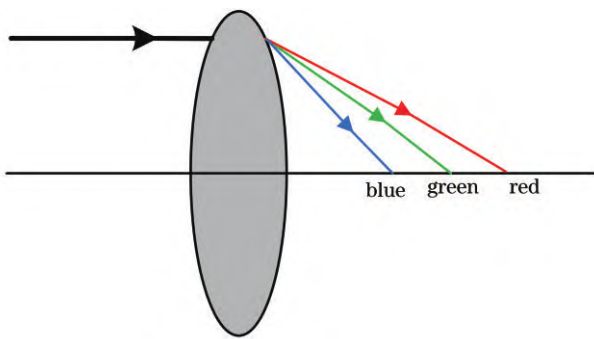

图 2 负透镜与内反面组合元件位置色差

Fig. 2 Position chromatic aberration of negative lens and inner reverse combination element

根据消色差理论,本研究采用折反射式结构校正色差以及二级光谱,折反射式结构如图 2 所示。带有内反面的负透镜元件光焦度为正值,光束经过元件后,波长较长的红光与光轴的焦点更近,波长较短的蓝光与光轴的焦点更远,不同波长与光轴交点位置与图 1 所示正透镜的位置色差相反。如图 3 所示,当透射式镜组与折反射式结构相互配合时,仅采用一种材料,就可以将系统的色差以及二级光谱校正,不需要考虑可

用于 DUV 谱段范围内玻璃材料少的问题。

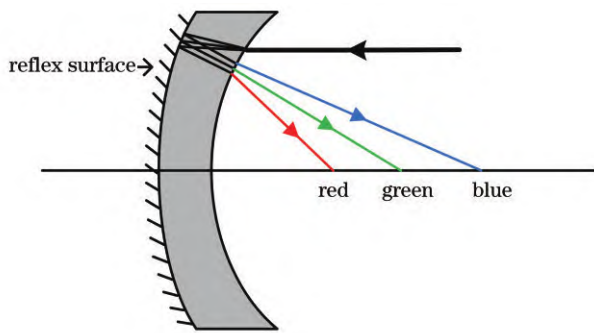

图 3 正透镜与折反射式结构组合消色差

Fig. 3 Combination of positive lens and catadioptric structure for achromatic aberration

### 3 高 NA 宽谱段物镜设计

#### 3.1 光学设计指标

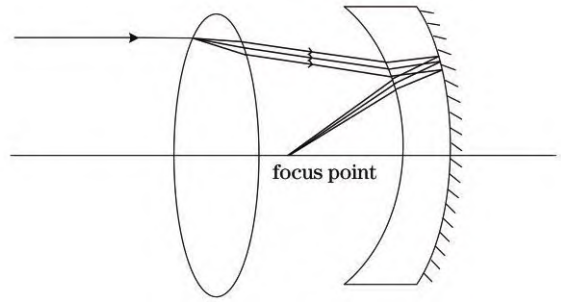
显微物镜比普通物镜对于像差更敏感,国外主要生产物镜的厂家如日本尼康、奥林巴斯等都对色差和场曲的校正提出了更高的要求,物镜类型也因此分为消色差物镜和平场物镜。根据高通量显微物镜的需求,为了提高基因测序光通量,需要提高数值孔径和视场,视场越大,检测面积越大,但是大视场检测还被探测器靶面尺寸所制约。同时,样本移动速率、像面画幅宽度与帧频都影响检测速度,基于以上分析,视场选为 0.3 mm,场曲小于 150 nm。光谱波段选用 DUV 到可见光波段(275~600 nm),在此波段通常使用的高透过率材料只有氟化钙和熔石英<sup>[9]</sup>,相对于氟化钙,石英硬度更大,可加工性和表面粗糙度更好,并且面形精度更高。因此,光学材料选取石英,系统主要设计指标如表 1 所示。

表 1 光学系统设计参数

Table 1 Design parameters of optical system

Parameter	Value
Wavelength /nm	275-600
Numerical aperture	0.91
Focal distance /mm	10.44
View of image height /mm	0.3
Field curvature /nm	150
Distortion /%	0.1
Telecentricity /mrad	5

#### 3.2 多光组系统初始结构

应用初级像差理论,利用光组正切计算公式计算多光组初始结构,具体如式(3)、(4)所示:

$$\tan u' = \tan u + h/f', \quad (3)$$

$$h_i = h_{i-1} - d_{i-1} \cdot \tan u'_{i-1}, \quad (4)$$

式中: $u_a (a=1, \dots)$ 为光线入射各个光组的孔径角; $\tan u$ 为光线入射光组孔径角的正切值; $u'_a$ 为光线出射各个光组的孔径角; $\tan u'$ 为光线出射光组孔径角的正

切值;  $h$  为光线入射光组的高度;  $f'$  为光组焦距值;  $d$  为光组之间间隔<sup>[10]</sup>。

在多光组计算过程中,只介绍位置色差计算(球差等初阶像差暂不作介绍)。对于多光组系统,其初级位置色差分布系数<sup>[11]</sup>的表达式为

$$C_{Cl} = h \tan u'(n_s - n_l) / n_m, \quad (5)$$

式中:  $n_s$  为材料的短波折射率;  $n_l$  为材料的长波折射率;  $n_m$  为材料的中波折射率。光组 1 为多光组系统前组,为透射式光学形式,可简化为正光焦度薄透镜。多光组系统后组为折反射式光学形式,将其简化为 3 薄透镜和 2 反射面。具体光路示意图如图 4、图 5 所示,其中,光线 3 次经过多光组系统后组的元件 3 和元件 4。



图 4 初始结构元件位置

Fig. 4 Initial structural element position

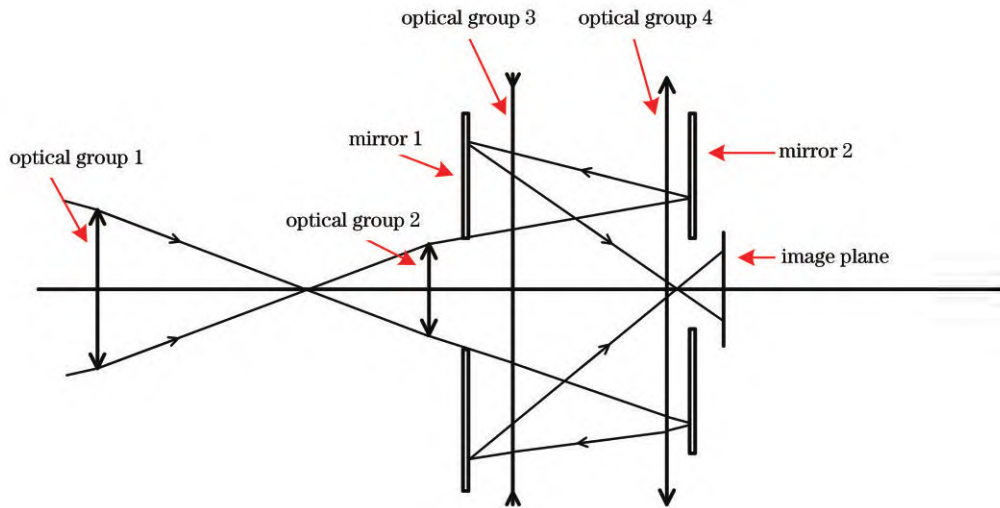

图 5 初始结构光线高度

Fig. 5 Initial structure light height

利用式(3)、(4)计算光线在各光组入射高度、入射孔径角及出射孔径角等光学数据,从而计算各光组焦距值,具体结果如表 2 所示。

利用式(5)计算多光组折反射式物镜位置色差系数,前组产生负向位置色差,后组产生正向位置色差,各光组的位置色差如图 6 所示。经过后组光学元件的补偿,系统整体位置色差接近 0。因此,折反射式物镜能够以单一材料实现宽波段范围内位置色差的校正。

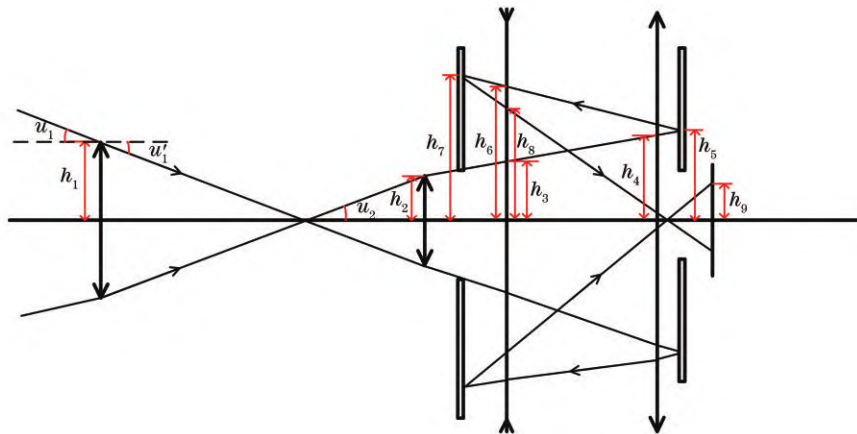
### 3.3 折反射式物镜光学设计

通过初始结构计算可知:前组像方数值孔径为 0.61,焦距为 17.44 mm;后组像方数值孔径为 0.91,焦距为 135.33 mm。通过光学设计软件 ZEMAX 进行

表 2 各光组焦距值

Table 2 Focus value of each light group

Optical group	Focal distance / mm
Group 1	17.383
Group 2	41.886
Group 3	-320.088
Group 4	564.142
Mirror 1	104.645
Mirror 2	20.02

优化设计,最终得到的光学系统光路图如图 7 所示,该系统由 12 片镜片组成,最后两片透镜为折反射式结





图 6 折反射物镜前后组位置色差系数

Fig. 6 Chromatic aberration coefficient of front and rear group positions of catadioptric objective

构,系统总长 127 mm,后工作距离为 0.75 mm,满足显微物镜使用需求。

系统全视场波像差如图 8 所示,在全视场全谱段

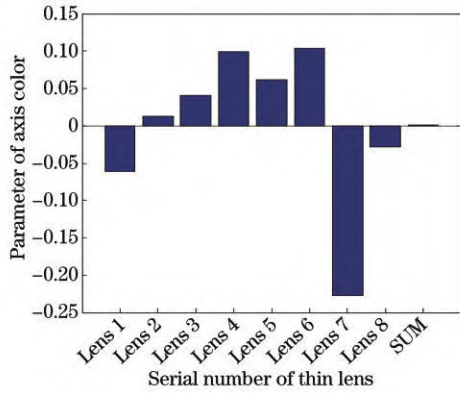

图 7 折反射式光学物镜

Fig. 7 Catadioptric optical objective lens

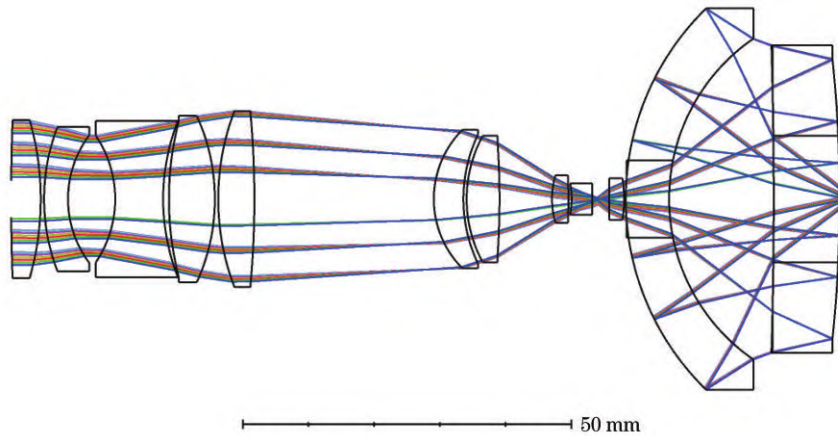

图 8 全视场全谱段波像差

Fig. 8 Full-spectrum wavefront aberration in full field of view

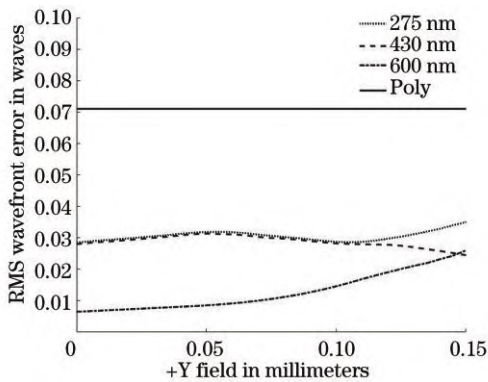

图 9 轴向色差曲线图

Fig. 9 Axial color difference curve

范围内波像差小于  $0.033\lambda$ ,轴向色差曲线图如图 9 所示,二级光谱为  $0.15\ \mu\text{m}$ ,校正了二级光谱,达到了复消色差的目的。系统场曲与畸变图如图 10(a)、(b)所示,单谱段场曲小于  $110\ \text{nm}$ ,系统最大畸变小于  $0.0001$ 。由于系统存在折反射式结构元件,系统中心遮拦为  $2.8\ \text{mm}$ 。中心孔径追迹情况如图 11 所示,光瞳进入视场光线所占比例仅为  $0.0006$ ,低通量的杂散光对光学系统成像没有影响<sup>[12]</sup>。

### 3.4 色焦移曲线

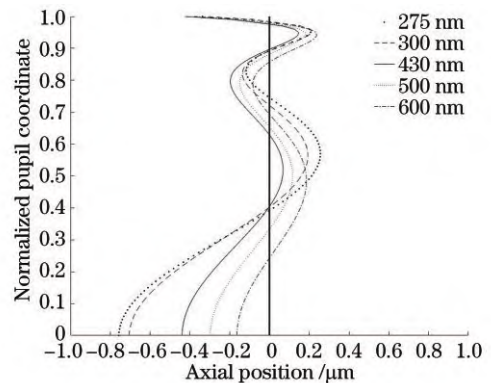
色焦移曲线是系统后焦距相对于主波长的偏移曲线图,当整个谱段色焦移曲线完全在衍射极限半径范围内,说明物镜位置色差得到很好校正,具体曲线如图 12 所示。无论应用在高端半导体检测领域还是基因测序领域,一般使用子谱段成像(如  $355\sim 405\ \text{nm}$ ,  $405\sim 450\ \text{nm}$  等),物镜在成像时不需要调焦就能够满足像质要求,极大提高了整机工作效率<sup>[13]</sup>。

## 5 结 论

随着科学技术的发展、生产工艺的进步,显微技术遇到更多严苛的挑战,对显微物镜提出了高数值孔径、大视场、宽谱段以及消色差的要求<sup>[14-15]</sup>。针对高数值

孔径折反射式物镜,利用折反射式物镜的光学特性,校正位置色差、计算出初始结构,最终实现采用单种玻璃材料在宽谱段范围内复消色差。经过光学设计软件优化,最终设计了一款数值孔径为  $0.91$ 、成像谱段为  $275\sim 600\ \text{nm}$  的折反射式物镜。结果表明:该物镜满



图 10 折反式光学物镜像差。(a)场曲;(b)畸变

Fig. 10 Image aberration of catadioptric optics. (a) Field curvature; (b) distortion

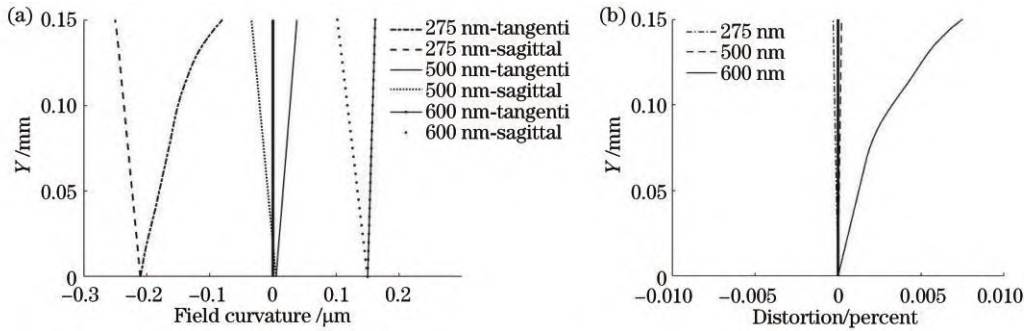

图 11 中心孔径光线追迹杂散光

Fig. 11 Center aperture ray tracing stray light

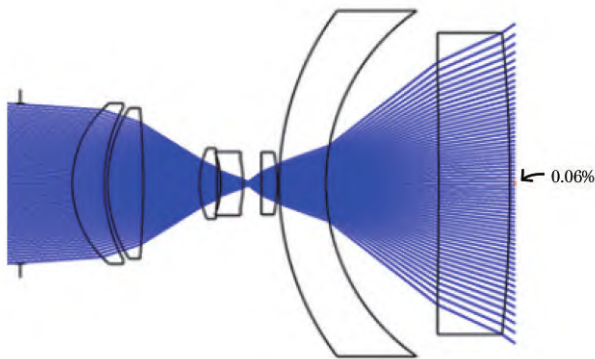

图 12 色焦移曲线

Fig. 12 Color focal shift curve

足总体指标要求;同时物镜色焦移曲线在衍射极限半口径范围内,整个物镜工作时不需要调焦,系统体积小,方便实际生产装配。相较于张新设计的显微物镜光学系统及光学设备,所设计系统采用非浸液式,针对特殊需求可以采用浸液的方式提高数值孔径,光谱波段到达深紫外波段,更贴近于目前项目需求。本研究聚焦于显微物镜的高精尖使用需求,设计了一款显微物镜,该物镜可以在基因测序、半导体晶圆缺陷检测以及生命科学等领域内广泛使用。

参 考 文 献

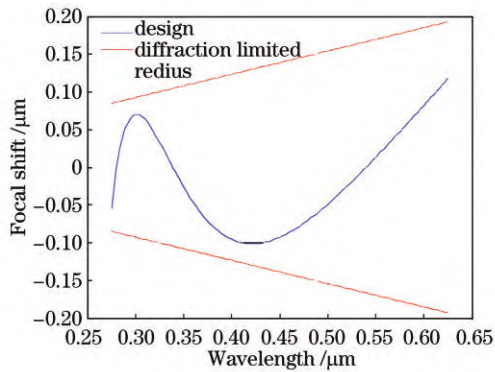
[1] 许伟才. 投影光刻物镜的光学设计与像质补偿[D]. 长春: 中国

科学院长春光学精密机械与物理研究所, 2011.

Xu W C. Optical design and imaging performance compensation for the lithographic lens[D]. Changchun: Changchun Institute of Optics, Fine Mechanics and Physics, Chinese Academy of Sciences, 2011.

[2] Cao Z, Li Y Q, Liu F. Grouping design method with real ray tracing model for extreme ultraviolet lithographic objective[J]. Optical Engineering, 2013, 52(12): 125102.

[3] 薛金来, 巩岩, 李佃蒙. N.A.0.75平场复消色差显微物镜光学设计[J]. 中国光学, 2015, 8(6): 957-963.

Xue J L, Gong Y, Li D M. Optical design of the N.A.0.75 plan-apochromatic microscope objective[J]. Chinese Optics, 2015, 8 (6): 957-963.

[4] Joseph A, Chuang Y H, David R. Catadioptric imaging system employing immersion liquid for use in broad band microscopy: US7633675[P]. 2009-11-15.

[5] 张新. 显微物镜光学系统及光学设备: CN108873289A[P]. 2018-11-23.

Zhang X. Microscope objective optical system and optical equipment: CN108873289A[P]. 2018-11-23.

[6] Shafer D R, Chuang Y H, Armstrong J J, et al. Small catadioptric microscope optics[J]. Physica A: Statistical Mechanics and its Applications, 2004, 5523:12-18.

[7] 李士贤, 郑乐年. 光学设计手册[M]. 北京: 北京理工大学出版社, 1990: 284.

Li S X, Zheng L N. Handbook of optical design[M]. Beijing: Beijing Institute of Technology Press, 1990: 284.

[8] Mao S S, Li Y Q, Jiang J H, et al. Design of a hyper-numerical-aperture deep ultraviolet lithography objective with freeform surfaces[J]. Chinese Optics Letters, 2018, 16(3): 030801.

[9] Levinson H J. High-NA EUV lithography: current status and outlook for the future[J]. Japanese Journal of Applied Physics, 2022, 61(SD): SD0803.

[10] Ishida K, Naruse K, Mizouchi Y, et al. Variable immersion microscopy with a high numerical aperture[J]. Optics Letters, 2021, 46(4): 856-859.

[11] 刘菲. 共轴极紫外投影光刻物镜设计研究[D]. 北京: 北京理工大学, 2014.

Liu F. Design and research of coaxial extreme ultraviolet projection lithography objective[D]. Beijing: Beijing Institute of Technology, 2014.

[12] 徐明飞. 高数值孔径投影光刻物镜的光学设计[D]. 长春: 中国科学院长春光学精密机械与物理研究所, 2015.

Xu M F. Optical design of the hyper numerical aperture lithographic lens[D]. Changchun: Changchun Institute of Optics, Fine Mechanics and Physics, Chinese Academy of Sciences, 2015.

[13] Stulen R H. 13-nm extreme ultraviolet lithography[J]. IEEE Journal of Selected Topics in Quantum Electronics, 1995, 1(3): 970-975.

[14] 刘晓林. 浸没式 ArF 光刻物镜的光学设计及像差控制[D]. 北

京: 北京理工大学, 2015.

Liu X L. Optical design and aberration control of immersion ArF lithography objective[D]. Beijing: Beijing Institute of Technology, 2015.

[15] 闫阿奇, 崔雯, 董森. 大变倍比光学被动半无热化变焦系统设

计[J]. 光学学报, 2022, 42(4): 0422001.

Yan A Q, Cui W, Dong S. Optical design of optical passive half-athermalization zoom lens with high zoom ratio[J]. Acta Optica Sinica, 2022, 42(4): 0422001.

## Design of Catadioptric Objective Lens with Hyper Numerical Aperture and Wide Spectral Band

Wang Chao<sup>1,2</sup>, Qu Hemeng<sup>1,2\*</sup>, Guan Haijun<sup>1,2\*\*</sup>, Wang Ha<sup>1</sup>, Zhang Jizhen<sup>1,2</sup>, Xie Xiaolin<sup>1,2</sup>, Wang Ning<sup>1</sup>

<sup>1</sup>Changchun Changguang Smart Optics Technology Company, Changchun 130102, Jilin, China;

<sup>2</sup>Changchun Institute of Optics, Fine Mechanics and Physics, Chinese Academy of Sciences, Changchun 130033, Jilin, China

### Abstract

**Objective** With the rapid development of high-tech fields such as gene sequencing, semiconductor chips, and life medicine, traditional microscopes are no longer able to meet the increasing technological needs. The microscopic objective lens, as the most core technical component in the microscopic system, is related to the imaging performance of the entire system and needs to meet conditions such as high numerical aperture, large field of view, and wide spectral range. When the imaging objective is located in the air, there is a theoretical limit to the numerical aperture of non-immersed structures. Therefore, non-immersed objective lenses with a high numerical aperture have become a technical challenge that Chinese surgical researchers urgently need to solve. The spectral range required in the field of gene sequencing is becoming shorter and shorter, moving towards ultraviolet and even deep ultraviolet. The wide spectral range causes an increasing color difference in the system, and ordinary application lenses do not need to correct the secondary spectrum. Microscopic objective lenses have extremely strict requirements for chromatic and spherical aberration and require correction. We focus on the technical requirements and current development trends of high-end microscopic objective lenses and design a catadioptric objective lens with a high numerical aperture and wide spectral band, with a numerical aperture of 0.91 and effective correction of color difference.

**Methods** We have designed a microscopic objective lens that eliminates secondary spectra within a wide spectral range. Usually, in order to eliminate axial color differences, a combination of positive and negative focal lenses of different materials is required for correction. By taking two lenses as an example, there is a significant difference in Abbe numbers and a small difference in optical power between the two lens materials. In order to further correct the secondary spectrum, it is necessary to have similar dispersion coefficients and significant differences in Abbe numbers between the two lens materials. However, for conventional lens materials, two-piece lenses fail to eliminate residual secondary spectra. For a catadioptric structure, a negative lens element with an inner reverse side has a positive focal power and an axial color difference direction opposite to the positive lens element. When both are used simultaneously, the axial color difference in the system can be completely corrected. By studying achromatic theory, we design a microscopic objective lens that eliminates secondary spectra within a wide spectral range.

**Results and Discussions** We use the optical design software ZEMAX to design a microscopic objective lens with a high numerical aperture and wide spectral range. Based on project requirements and optical system design indicators, the design results are analyzed. According to the primary aberration theory and the characteristics of apochromatic aberration in the catadioptric structure, the power of each light group in the initial structure is calculated, and the specific values are shown in Table 2. The aperture of the first group is 0.61, and the focal length is 17.44 mm; the aperture of the latter group is 0.91, and the focal length is 135.33 mm. After optimizing and analyzing the initial structure, the final optical path map of the optical system is obtained. As shown in Fig. 7, the system consists of 12 lenses with only one material. As shown in Fig. 9, the dipole spectrum value is 0.15  $\mu\text{m}$ . This indicates that the secondary spectrum has been positively corrected. As shown in Fig. 10, the single segment field curvature of the system is less than 110 nm, and the maximum distortion of the system is less than 0.0001. As shown in Fig. 12, the color focal shift curves of all wavelengths in the system are

within the diffraction limit radius range, indicating that the color difference at the system position has been well corrected.

**Conclusions** With the development of science and technology and the progress of production processes, microscopy needs to meet the strict technical requirements of more industries, such as gene sequencing and semiconductor chip fields, which require microscopy objective lenses to have a high numerical aperture, large field of view, and wide spectral band achromatic ability. The optical system lens components designed in this article only use one material, eliminating the secondary spectrum in the range of 275–600 nm from the deep ultraviolet spectrum to the visible spectrum, solving the problem of traditional achromatic aberration requiring multiple materials to cooperate, and removing the pain point of less available glass materials in the ultraviolet band. Based on the existing research results of the project team, an optical system with a larger numerical aperture and shorter light transmission wavelength has been designed. From the design results, it can be seen that the system has a small volume and is convenient for actual production assembly. It can be widely used in fields such as semiconductor wafer defect detection and gene sequencing.

**Key words** hyper numerical aperture; deep ultraviolet; catadioptric objective lens; achromatism