

Order parameters of the liquid crystal interface layer at a rubbed polymer surface

Li Xuan, Takeshi Tohyama, Tetsuya Miyashita, and Tatsuo Uchida

Citation: *J. Appl. Phys.* **96**, 1953 (2004); doi: 10.1063/1.1772881

View online: <http://dx.doi.org/10.1063/1.1772881>

View Table of Contents: <http://jap.aip.org/resource/1/JAPIAU/v96/i4>

Published by the [American Institute of Physics](#).

Related Articles

Structure simulation of ultrathin dichloromethane layer on a solid substrate by density functional theory and molecular dynamics simulations

J. Chem. Phys. **137**, 074705 (2012)

Photomechanical bending mechanics of polydomain azobenzene liquid crystal polymer network films

J. Appl. Phys. **112**, 013513 (2012)

Decomposition driven interface evolution for layers of binary mixtures. III. Two-dimensional steady films with flat and modulated surfaces

Phys. Fluids **24**, 062109 (2012)

Size control of vapor bubbles on a silver film by a tuned CW laser

AIP Advances **2**, 022155 (2012)

A model for the human tear film with heating from within the eye

Phys. Fluids **24**, 062103 (2012)

Additional information on *J. Appl. Phys.*

Journal Homepage: <http://jap.aip.org/>

Journal Information: http://jap.aip.org/about/about_the_journal

Top downloads: http://jap.aip.org/features/most_downloaded

Information for Authors: <http://jap.aip.org/authors>

ADVERTISEMENT



AIP Advances

Special Topic Section:
PHYSICS OF CANCER

Why cancer? Why physics? [View Articles Now](#)

Order parameters of the liquid crystal interface layer at a rubbed polymer surface

Li Xuan^{a)}

Department of Electronics, Graduate School of Engineering, Tohoku University, 05, Aoba, Aramaki, Sendai, 980-8579, Japan and State Key Laboratory of Applied Optics, Changchun Institute of Optics, Fine Mechanics and Physics, Chinese Academy of Sciences, Changchun, 130033, People's Republic of China

Takeshi Tohyama, Tetsuya Miyashita, and Tatsuo Uchida

Department of Electronics, Graduate School of Engineering, Tohoku University, 05, Aoba, Aramaki, Sendai, 980-8579, Japan

(Received 27 January 2003; accepted 23 May 2003)

In this paper, the liquid crystal (LC) order parameters of the interface layers at rubbed polymer surfaces were studied. The LC films in this study were made with either polyvinyl alcohol or polyimide and the test LCs were filled into wedge-shaped cells for various measurements. The real distribution of order parameters from LC bulk to the interface was obtained by measuring the anisotropic infrared absorbance of sample films. It was found that the order parameters start to decrease where the LC layer thickness is smaller than 10 nm, and the order parameter of LC monolayer at the rubbed polymer surface is only 1/3–1/2 of that of the LC bulk even in a strong rubbing condition. When the temperature was increased to the transition point, the LC interface layer (excluding the adsorption monolayer) completed the phase transition while the bulk layer remained in LC phase. This was a further evidence that the order parameter of the interface layer is lower than that of the bulk. © 2004 American Institute of Physics. [DOI: 10.1063/1.1772881]

I. INTRODUCTION

It is still unclear that what the magnitude of order parameters in the alignment film is needed to keep the bulk liquid crystal (LC) alignment stable. In this work, the order parameter of LC monolayer on the surface of polyvinyl alcohol (PVA) and polyimide (P) films treated by rubbing was studied. Since rubbed PI alignment films are widely applied in industrial fabrication process of LC display devices and rubbed PVA alignment films are popularly used in laboratories, the experimental results have practical significance. More important, this work provides an order parameter criterion to the new alignment techniques, for example, the photoalignment technique.^{1–3}

A large number of semiquantitative and some quantitative analysis^{4–18} of the order parameter of LC near rubbed polymer films surfaces were reported. The work similar to the current study were made by Hallam *et al.*¹⁹ and Nishikawa and West.²⁰ Hallam *et al.* deduced the temperature dependent surface and bulk order parameters of homogeneous aligned LC using azimuthal anchoring strength calculated by the twist angle changed from the temperature 30 °C lower than the phase transition point until near to the transition point. The authors seemed to omit the possibility that the increasing twist angle with temperature might be mainly due to a decreased elastic constant K_{22} rather than the surface anchoring strength, and they assumed that the surface order parameter was 1.0 at 0 K but omit the effect of the surface morphology still held for the surface order as well. Nishikawa and West reported distributions of the order param-

eters with changed cell gaps. In the current study, we will present experimental results on the distribution of the order parameters from the bulk to the surface with finite interface layer thickness. To further verify our result, we also increased temperature to show where the phase transition started, i.e., at the interface layer or inside the bulk.

II. EXPERIMENT

Order parameters of a nematic LC can be obtained by measuring its anisotropic property. In the present study, order parameters were obtained by measuring the infrared (IR) dichroism of sample films. If the nematic LC molecule has a group with IR active bond vibration parallel to the molecular long axis, the IR absorbance due to the group can be a measure of the orientation order of LC molecules. In this technique, we defined A_{\parallel} and A_{\perp} as the IR absorbance measured when the polarization of a incident light was parallel or perpendicular to the long axis of LC molecules, respectively. When A_{\parallel} is not equal to A_{\perp} , the sample is dichroic with nonzero scalar order parameter, i.e., it is optically anisotropic. From the measured A_{\parallel} and A_{\perp} values we can evaluate the order parameter for nematic LC films made from molecules with uniaxial symmetry by using the following equation:

$$\bar{Q}_d = \frac{A_{\parallel} - A_{\perp}}{A_{\parallel} + 2A_{\perp}}. \quad (1)$$

Since the measured absorbance always contains information from the bulk layer and the two interface layers, the order parameter \bar{Q}_d is the average value of these layers.

^{a)}Electronic mail: xuanli@ciomp.ac.cn

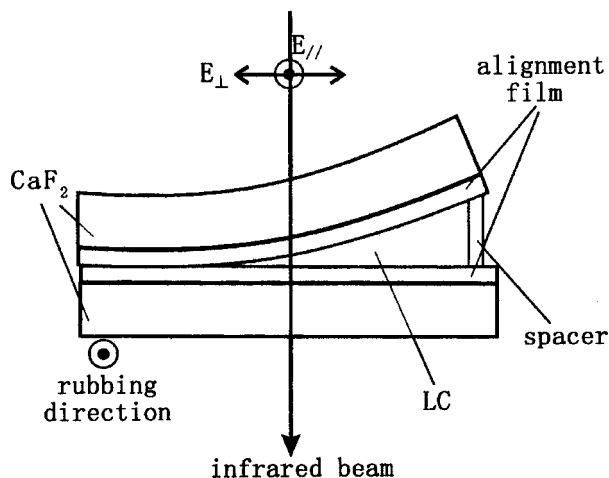

FIG. 1. A schematic drawing of a wedge-shaped LC cell.

When the thickness of LC films gradually decreases toward 0, we can measure thickness dependence of A_{\parallel} and A_{\perp} , i.e., thickness dependence of the order parameter. From the measurement, we can then evaluate the magnitude of order parameter at the surface by extrapolating the result to zero thickness of the layer.

To obtain continuously changed LC layer thickness with a constant surface alignment condition, a wedge-shaped LC cell was used.

For the dichroic liquid crystals, the volume average absorbance, A , can be expressed as

$$A = \frac{1}{3}(A_{\parallel} + 2A_{\perp}), \quad (2)$$

where A is proportional to the thickness of LC layer thickness d . To obtain thickness dependence of the order parameter, one can obtain the relationship between A and d first and then measure A_{\parallel} and A_{\perp} . Both the LC layer thickness and the order parameter can then be calculated from A_{\parallel} and A_{\perp} data. There are three different measurement techniques one can choose to use for measuring the thickness d of a LC layer depending on the range of the layer thickness. When d is in the micrometer range, the interference of the two reflected beams from the two inner surfaces of the cell can be used to obtain the cell gap which equals to the thickness of the LC layer. If LC layer thickness d is in the range of hundreds of nanometers, an ellipsometer can be used for measuring the retardation of the LC layer and then dividing the result by Δn to obtain d , where Δn is the difference value of the anisotropic refractive indices measured by Abbe refractometer. When d is smaller than 100 nm, the thickness can be measured by reflected ellipsometry in isotropic phase.

The geometry of a wedge-shaped LC cell is shown in Fig. 1, where two pieces of CaF_2 substrates ($20 \times 10 \times 0.2 \text{ mm}^3$), are used because CaF_2 is transparent in IR region. The cell gap ranges from 0 to $2 \mu\text{m}$ over a substrate edge length of 20 mm. The inner surfaces of the wedge cell were spin coated with PVA (#500) or polyimide AL-1051 (main chain, JSR Co. Ltd), and unidirectionally rubbed along the substrate edge of 10 mm, with a strong rubbing strength of $L=1000 \text{ cm}$, which is described in detail elsewhere.^{21,22}

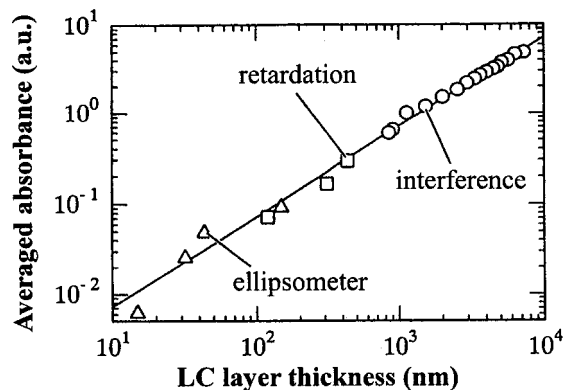

FIG. 2. Plot of the average absorbance vs LC layer thickness.

Nematic LC GR-41 (Chisso Co. Ltd) with a N-I transition point of 68°C was injected into the wedge cell at 80°C and then naturally cooled down to the room temperature. All the composites have $-\text{C}\equiv\text{N}$ groups in which the bound vibration is parallel to the long axis of the molecules, and the absorbance of $-\text{C}\equiv\text{N}$ groups was utilized for measuring the LC molecular order.^{23,24}

A Fourier-transfer-infrared (FT-IR) spectrometer (FTS3000, Bio-Rad Co. Ltd) was used to measure A_{\parallel} and A_{\perp} of the LC layer. The tested beam of a diameter of 1 mm was normal to the sample cell surface, and a polarizer was placed in front of the sample. A_{\parallel} and A_{\perp} were measured with the polarizer parallel and perpendicular to the rubbing direction, respectively. An ellipsometer (Shimatsu, AEP-100) was used to measure the retardation and the thickness of LC layers. The diameter of a He-Ne laser beam is 1 mm.

III. RESULTS

The vibration absorbance peak of $-\text{C}\equiv\text{N}$ is at 2225 cm^{-1} , which was used for the absorption measurement in this experiment. The measured linear relationship between A and d for a LC layer is shown in Fig. 2, where the data points marked by "O" were obtained by an interference method, "□" by a retardation measurement, and "Δ" by reflected ellipsometry.

Figure 3 shows the absorbance of the wedge cell when the polarizer was set parallel and perpendicular to the rub-

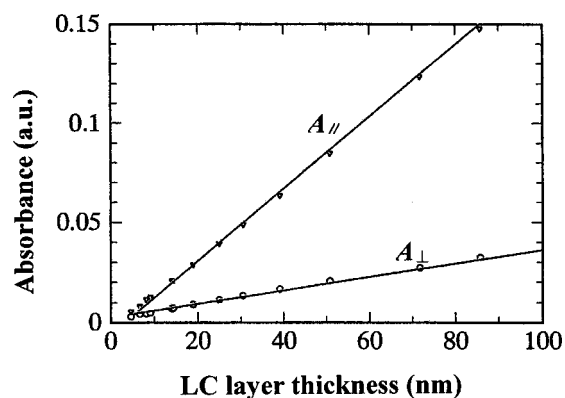
FIG. 3. Plot of absorbance parallel (A_{\parallel}) and perpendicular (A_{\perp}) to the rubbing direction (PVA alignment film, rubbing strength 1000 cm).

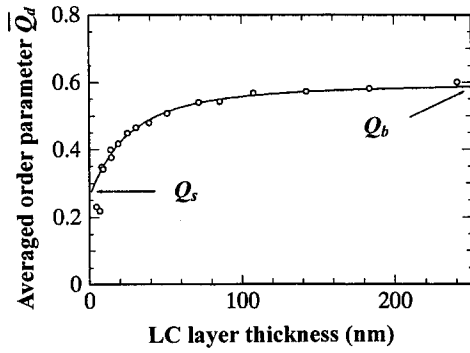

FIG. 4. The averaged order parameters vs LC layer thickness (PVA alignment film, rubbing strength 1000 cm).

bing direction and the result suggests that the difference between A_{\parallel} and A_{\perp} varies with the thickness of LC layer aligned by the rubbed PVA film. The measurement was performed in 28 °C. The two solid lines are the continuation from the bulk results which crossed in the point of several nanometers thickness where the experimental dots indicate $A_{\parallel} \neq A_{\perp} \neq 0$. In fact, if the order parameter in the interface layer is larger than that in the bulk, the two continuation lines will cross at the point of $d < 0$. If the order parameter in the interface layer is smaller than that in the bulk, the two continuation lines will cross at a point where $d > 0$. When the order parameter in the interface layer is the same with that in the bulk, the two continuation lines will cross at the point of $d = 0$. Our experimental result suggested that the second case hold in our experiment. Therefore we concluded that the order parameter at the surface was smaller than that in the bulk.

Using Eq. (1) and data in Fig. 3 we derived the distribution of the averaged order parameters along the LC layer thickness direction and the result is shown in Fig. 4. It can be seen that the averaged order parameter decreases quickly when the thickness of the LC layers is smaller than 100 nm. At the point of $d = 0$, i.e., on the surface of rubbed PVA film, the LC order parameter is only about 0.25, while the order parameter approaches to saturation value of 0.6, i.e., the bulk order parameter, when the thickness becomes larger than 100 nm.

The rubbing strength on the PVA surface is 100 cm. According to our experiments, when the rubbing strength reaches 300 cm, the surface order parameter becomes saturated. Therefore we can say that the order parameter decreases quickly where approaches to the surface, and the surface order parameter is only up to $1/3 - 1/2$ of the bulk order parameter, regardless how strong the rubbing strength is. A similar result was achieved in polyimide films.^{17,18}

The solid line in Fig. 4 is a fitted curve according to Yokoyama's assumption of the distribution of order parameters in a LC cell.¹³

$$Q(z) = Q_b + (Q_s - Q_b) \exp\left(-\frac{z}{\xi}\right), \quad (3)$$

where z is the thickness of LC layer which starts from the surface of one substrate, as shown in Fig. 5, Q_b and Q_s are the LC order parameters in bulk and on the rubbed film

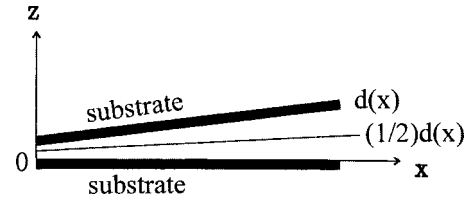

FIG. 5. A schematic of the coordinate of the wedge shaped cell.

surface respectively, and ξ is coherent length which is taken as the interface layer thickness.

Because the interface layers are the two inner surfaces of substrates, the distribution of order parameters is symmetric to the line of $(1/2)d(x)$. If \bar{Q}_d is the integrating averaged value of $Q(z)$, one can obtain \bar{Q}_d by using the following equation:

$$\begin{aligned} \bar{Q}_d &= \frac{2}{d} \int_0^{d/2} Q(z) dz = \frac{2}{d} \int_0^{d/2} \left[Q_b - (Q_b - Q_s) \exp\left(-\frac{z}{\xi}\right) \right] dz \\ &= Q_b + \xi(Q_b - Q_s) \frac{2}{d} \left[\exp\left(-\frac{d(x)}{2\xi}\right) - 1 \right], \end{aligned} \quad (4)$$

where $d(x)$ is a measurable parameter, Q_s and ξ are fitting parameters. By fitting experimental \bar{Q}_d with Eq. (4), as shown in Fig. 4, $\xi = 7$ nm and $Q_s = 0.25$ were obtained, respectively.

Transforming \bar{Q}_d into $Q(z)$, we obtain the real distribution of order parameters from bulk to the interface as shown in Fig. 6. It is obvious that the order parameters start to decrease after the LC layer thickness is smaller than 10 nm. The layer thickness of 10 nm is the same as the molecular coherent length proposed by P. G. de Gennes,²⁵ which suggests that any interruption in LC will disappear over the range of 10 nm.

The experimental results prove that the order parameter of LC on the rubbed surface of an alignment film is much smaller than that in bulk and Q_s is estimated about $1/3 Q_b - 1/2 Q_b$, even under saturated rubbing condition. This suggests that the rubbing treatment cannot completely control the molecular orientation, but only offer an alignment axis and an essential orientational order.¹⁵ In addition, the order parameter can be quickly recovered at the interface layer by the molecular interaction.

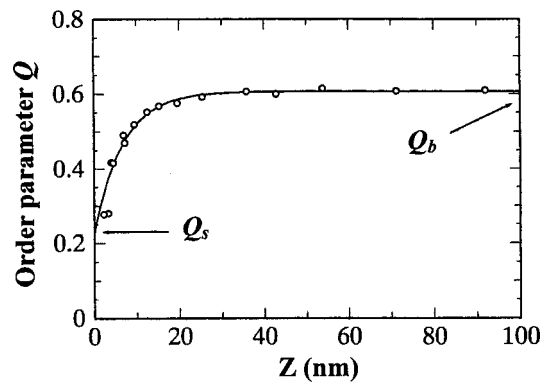

FIG. 6. The distribution of order parameters of LC molecules in the surface layer (PVA alignment film, rubbing strength 1000 cm).

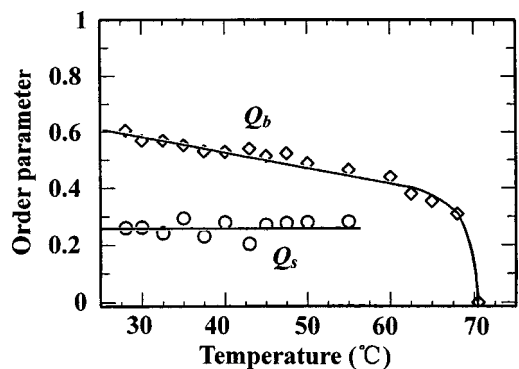

FIG. 7. A plot of bulk order parameters (Q_b) and the surface order parameters (Q_s) vs temperature (PVA alignment film, rubbing strength 1000 cm).

To further study the surface order parameter Q_s , we heated the wedge cell to the transition point from nematic to isotropic phase, and measured the order parameters as a function of the temperature. As shown in Fig. 7, the bulk order parameter Q_b decreased linearly when the temperature did not exceed 60 °C. However, at a temperature about 10 °C lower than the transition point, Q_b decrease quickly

with further increase of temperature until it reached 0 at 70 °C. On the other hand, Q_s remained unchanged until temperature reached 55 °C that is 13 °C lower than the transition point. The measurement of Q_s at temperature higher than 55 °C becomes impossible because the thin part of LC layer in the wedge cell started phase transition at a temperature not much higher than 55 °C. We observed phase transition spreading from the thin part of the films to the thick part. To further understand the changing process of the order parameters, the dependence of $A_{||}$ and A_{\perp} on LC layer thickness was measured at temperatures from 28 to 70 °C. The result of this measurement is shown in Fig. 8. It can be seen from this data that, at temperatures from 28 to 55 °C, the value of $A_{||}-A_{\perp}$ decreases linearly with the LC layer thickness, but at 60 °C and when the interface layer thickness is several nanometers, the value of $A_{||}-A_{\perp}$ hardly changes. At 68 °C, the transition point of LC bulk, the thickness of the layer with an almost unchanged value of $A_{||}-A_{\perp}$ increases, up to 15 nm. The tendency continues until 70 °C while the phase transition completes.

The curve of $A_{||}-A_{\perp}$ vs LC layer thickness measured at 68 °C is plotted in Fig. 9, where a is the total distribution of

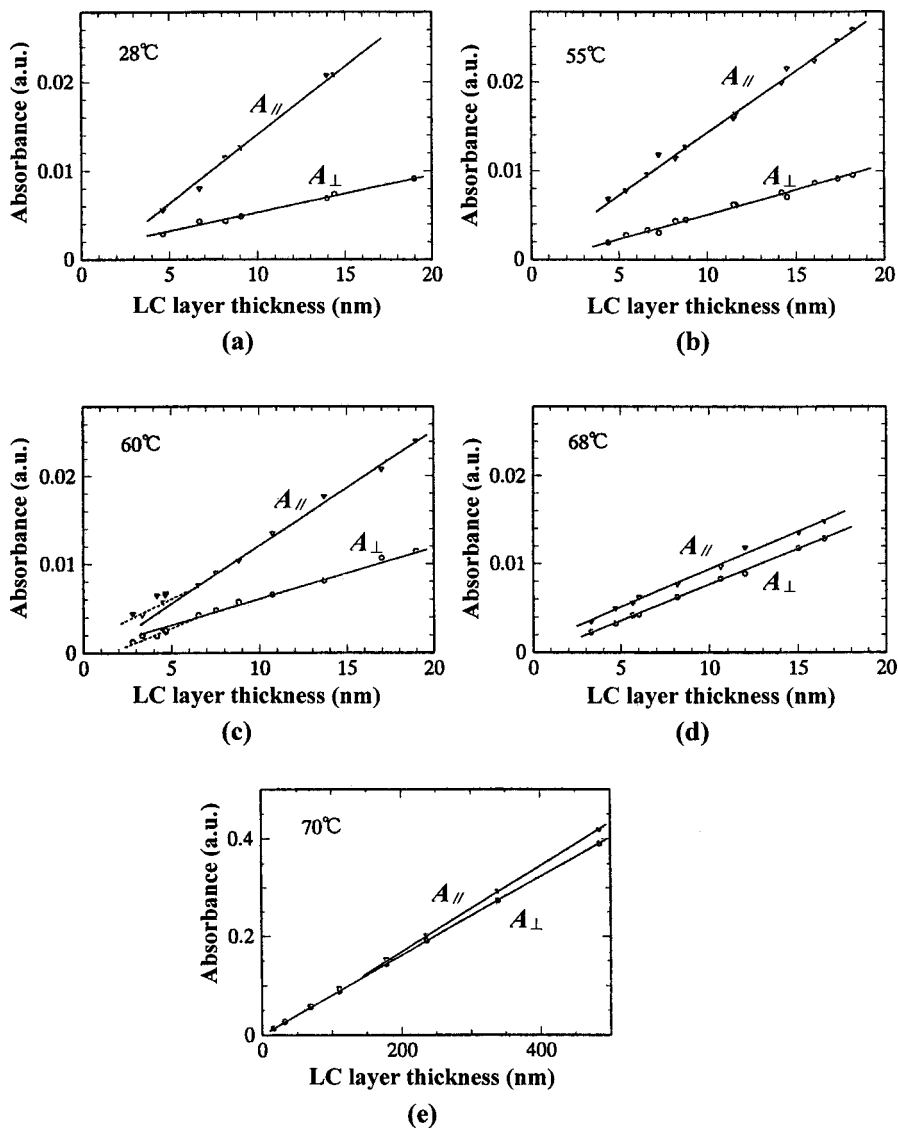

FIG. 8. The absorbance of $A_{||}$ and A_{\perp} measured at (a) 28 °C, (b) 55 °C, (c) 60 °C, (d) 68 °C, and (e) 70 °C.

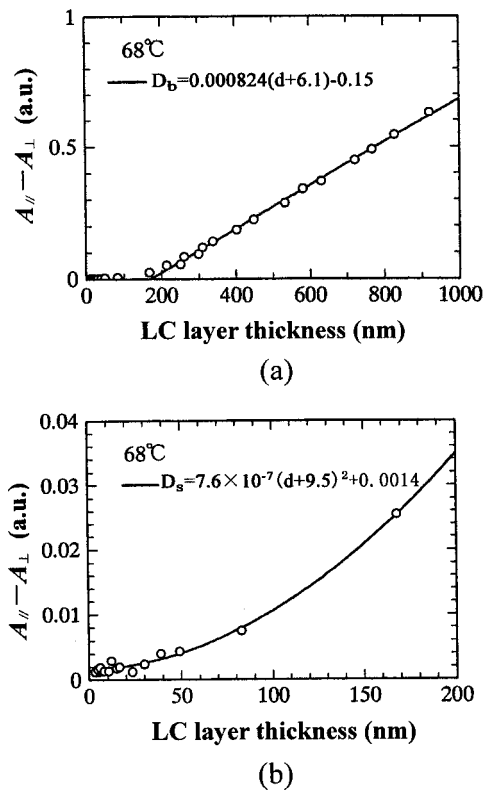

FIG. 9. A plot of $A_{\parallel}-A_{\perp}$ vs LC layer thickness measured at 68 °C: (a) the distribution in the bulk layer fitting into a line $D_b=0.000824(d+6.1)-0.15$; (b) the details of the distribution near the surface layer fitting into a curve $D_s=7.6 \times 10^{-7}(d+9.5)^2+0.0014$.

$A_{\parallel}-A_{\perp}$ and b is the enlargement of the initial part of the curve. From Fig 9(a) with Fig. 9(b), it can be seen that the curve at the thickness of 200 nm appears to have a sudden change in curvature, and the value of $A_{\parallel}-A_{\perp}$ is close to 0 where the thickness is smaller than 200 nm. This suggests that the interface layers on the upper and bottom substrates, totally about 200 nm of thickness, have entered phase transition. The relatively low value of $A_{\parallel}-A_{\perp}$ shown in Fig. 9(b) can be attributed to mainly the short-range order of the LC layer because it is thickness dependent and very little to the adsorbed monolayer's order because the adsorption energy should be much larger than the nematic-isotropic enthalpy. From this result we may deduce the distribution of phase states in the LC cell at transition point, as shown in Fig. 10, in which phase transition happens earlier in the LC interface layer than the bulk and the adsorbed monolayer remains in the nematic state. The lower the order parameter is, the higher the free energy becomes. The fact of the LC interface layer enters phase transition earlier suggests that Q_s is smaller than Q_b .

In addition, the value of $A_{\parallel}-A_{\perp}$ in Fig. 9(b) appears to have a quadratic relationship with the LC layer thickness and we believe that the phenomenon may be due to the size increase of the short-range order domains with increasing LC layer thickness.

It should be noted that our interpretation is based on the phenomena on a heating process, because heating process is simple and without the complexity of the nucleation energy. We believe that the conclusion should hold for a cooling

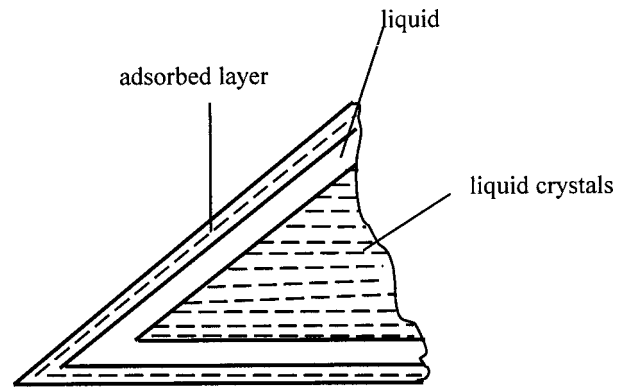

FIG. 10. A schematic drawing to show the coexistence of the nematic phase and isotropic phase at transition point.

process in which a nematic phase appears at surface first as described by previous works.^{26,27} Because the transition from isotropic to nematic requires a nucleation energy that should be much larger than the energy caused by the difference of Q_s and Q_b , the substrate wall provides nucleation sites so that nematic LC appear at surface first no matter how smaller of Q_s than Q_b .

IV. CONCLUSION

From the research results, we concluded that the LC order parameter at the rubbed surface of alignment films was about 1/3–1/2 of the value for the bulk, regardless what type of the alignment film was used, i.e., PVA or PI, and regardless how strong the rubbing treatment was applied on the film, and we found in our study that the order parameter quickly recovered at the interface layer which thickness was about 10 nm. Due to the limitations of the measurement methods used in this research, we did not taken into account the two-dimensional alignment effect on the surface, that is, the molecules tend to lie down on the substrate surfaces. Since we studied the order parameters of LC layers with a uniaxial symmetry, the surface order parameters obtained in our research are expected to be slightly smaller than the actual values.

ACKNOWLEDGMENT

The research was supported in part by Chinese NSFC Grant Nos. (19974046, 59973020, and 60277033), Science Foundation of Jilin Province Grant Nos. (20010579 and 20020603).

- ¹W. M. Gibbons, P. J. Shannon, S. T. Sun, and B. J. Swetlin, *Nature* (London) **351**, 49 (1991).
- ²Y. X. Tang, D. S. Liu, P. Xie, and R. B. Zhang, *Macromol. Rapid Commun.* **17**, 759 (1996).
- ³Y. Q. Tian, Y. Z. Ren, R. P. Sun, Y. Y. Zhao, X. Y. Tang, X. M. Huang, and S. Q. Xi, *Liq. Cryst.* **22**, 177 (1997).
- ⁴C. S. Mullin, P. Guyotsionnest, and Y. R. Shen, *Phys. Rev. A* **39**, 3745 (1989).
- ⁵W. Chen, M. B. Feller, and Y. R. Shen, *Phys. Rev. Lett.* **63**, 2665 (1989).
- ⁶Y. Ouchi, M. B. Feller, T. Moses, and Y. Y. Shen, *Phys. Rev. Lett.* **68**, 3040 (1992).
- ⁷E. S. Lee, P. Vetter, T. Miyasita, T. Uchida, M. Kano, M. Abe, and K. Sugawara, *Jpn. J. Appl. Phys., Part 2* **32**, L1436 (1993).
- ⁸K. Sakamoto, R. Arafune, N. Ito, S. Ushioda, Y. Suzuki, and S.

- Morokawa, J. Appl. Phys. **80**, 431 (1996).
- ⁹E. G. Hanson and Y. R. Shen, Mol. Cryst. Liq. Cryst. **36**, 193 (1976).
- ¹⁰H. Hsiung, T. Rasing, and Y. R. Shen, Phys. Rev. Lett. **57**, 3065 (1986).
- ¹¹T. Moses and Y. R. Shen, Phys. Rev. Lett. **67**, 2033 (1991).
- ¹²W. Chen, L. J. Martinezmiranda, and H. Hsiung, Phys. Rev. Lett. **62**, 1860 (1989).
- ¹³H. Yokoyama, S. Koyayashi, and H. Kamei, J. Appl. Phys. **61**, 4501 (1987).
- ¹⁴H. Yokoyama, J. Chem. Soc., Faraday Trans. 2 **84**, 1023 (1988).
- ¹⁵T. Shioda, Y. Okada, D. H. Chung, Y. Takanishi, K. Ishikawa, B. Park, and H. Takezoe, Jpn. J. Appl. Phys., Part 1 **41**, L266 (2002).
- ¹⁶S. Araki, P. Gautier, T. Oshima, T. Miyashita, and T. Uchida, in *Proceedings of the IDW'00* (SID, Kobe, 2000), p. 69.
- ¹⁷H. Ueno, L. Xuan, T. Tohyama, T. Miyashita, and T. Uchida, in *Proceedings of the SID, Canada, 1997*.
- ¹⁸H. Ueno, L. Xuan, T. Miyashita, and T. Uchida, in the Conference of International Liquid Crystal, Strasbourg, 1998, Vol. P2, p. 176.
- ¹⁹B. T. Hallam, C. V. Brown, and J. R. Sambles, J. Appl. Phys. **86**, 6682 (1999).
- ²⁰Michinori Nishikawa and John L. West, Jpn. J. Appl. Phys., Part 1 **38**, L331 (1999).
- ²¹T. Uchida, M. Hirano, and H. Sakai, Liq. Cryst. **5**, 1127 (1989).
- ²²Y. Sato, K. Sato, and T. Uchida, Jpn. J. Appl. Phys., Part 1 **31**, L579 (1992).
- ²³L. Xuan and Ximin Huang, Chinese J. Liq. Cryst. Displ. **14**, 153 (1999).
- ²⁴L. Xuan and Ximin Huang, Chinese J. Liq. Cryst. Displ. **15**, 6 (2000).
- ²⁵P. G. De Gennes and J. Prost, *The Physics of Liquid Crystals*, 2nd ed., New York, 1993, Vol. 82.
- ²⁶H. Yokoyama, S. Kobayashi, and H. Kamei, Mol. Cryst. Liq. Cryst. **99**, 39 (1983).
- ²⁷M. Miyano, Phys. Rev. Lett. **43**, 51 (1979).