

This article was downloaded by: [Changchun Institute of Optics, Fine Mechanics and Physics]

On: 04 September 2012, At: 20:34

Publisher: Taylor & Francis

Informa Ltd Registered in England and Wales Registered Number: 1072954 Registered office: Mortimer House, 37-41 Mortimer Street, London W1T 3JH, UK



## Liquid Crystals

Publication details, including instructions for authors and subscription information:

<http://www.tandfonline.com/loi/tlct20>

### Effect of the twisted alignment on the liquid crystal wave-front corrector

Zhaoliang Cao<sup>a b</sup>, Quanquan Mu<sup>a b</sup>, Guillaume Dovillaire<sup>c</sup>, Thomas Grandin<sup>c</sup>, Emeric Lavergne<sup>c</sup>, Lifa Hu<sup>a</sup> & Li Xuan<sup>a</sup>

<sup>a</sup> State Key Laboratory of Applied Optics, Changchun Institute of Optics, Fine Mechanics and Physics, Chinese Academy of Sciences, Changchun 130033, P. R. China

<sup>b</sup> Graduate School of Chinese Academy of Sciences, Beijing 100049, P. R. China

<sup>c</sup> Imagine Optic, 18 rue Charles de Gaulle, 91400 Orsay, France

Version of record first published: 29 Oct 2007

To cite this article: Zhaoliang Cao, Quanquan Mu, Guillaume Dovillaire, Thomas Grandin, Emeric Lavergne, Lifa Hu & Li Xuan (2007): Effect of the twisted alignment on the liquid crystal wave-front corrector, *Liquid Crystals*, 34:10, 1227-1232

To link to this article: <http://dx.doi.org/10.1080/02678290701658274>

PLEASE SCROLL DOWN FOR ARTICLE

Full terms and conditions of use: <http://www.tandfonline.com/page/terms-and-conditions>

This article may be used for research, teaching, and private study purposes. Any substantial or systematic reproduction, redistribution, reselling, loan, sub-licensing, systematic supply, or distribution in any form to anyone is expressly forbidden.

The publisher does not give any warranty express or implied or make any representation that the contents will be complete or accurate or up to date. The accuracy of any instructions, formulae, and drug doses should be independently verified with primary sources. The publisher shall not be liable for any loss, actions, claims, proceedings, demand, or costs or damages whatsoever or howsoever caused arising directly or indirectly in connection with or arising out of the use of this material.

# Effect of the twisted alignment on the liquid crystal wave-front corrector

ZHAOLIANG CAO<sup>†‡</sup>, QUANQUAN MU<sup>†‡</sup>, GUILLAUME DOVILLAIRE<sup>§</sup>, THOMAS GRANDIN<sup>§</sup>, EMERIC LAVERGNE<sup>§</sup>, LIFA HU<sup>†</sup> and LI XUAN<sup>\*†</sup>

<sup>†</sup>State Key Laboratory of Applied Optics, Changchun Institute of Optics, Fine Mechanics and Physics, Chinese Academy of Sciences, Changchun 130033, P. R. China

<sup>‡</sup>Graduate School of Chinese Academy of Sciences, Beijing 100049, P. R. China

<sup>§</sup>Imagine Optic, 18 rue Charles de Gaulle, 91400 Orsay, France

(Received 14 June 2007; accepted 31 August 2007)

The effect of twisted alignment on the phase modulation of a liquid crystal wave-front corrector was investigated. First, the effect of twisted alignment is discussed in terms of the modulation principle of the liquid crystal molecule. Only partial incident light can be modulated because of the effect of the twisted alignment. Other unmodulated light will affect the correction accuracy and the resolution of the image. The blazed grating method is proposed to solve this problem. Adaptive correction was performed without the blazed grating method and the correction results are poor. A similar adaptive correction experiment was performed with the blazed grating method and a better correction result is obtained. The residual averaged wave-front errors are  $PV=0.101\lambda$  and  $RMS=0.015\lambda$  and a resolvable image is obtained.

## 1. Introduction

A liquid crystal display (LCD) can be used to modulate spatial light since it has phase modulation characteristics. The twisted nematic liquid crystal spatial light modulator (TN LCSLM) has been investigated in many papers [1–8] since it is inexpensive and can be fabricated easily with LCD technology. TN LCSLM has the potential to be used as a wave-front corrector (WFC) in an adaptive optics system to correct the distorted wave-front. However, it has the disadvantage of amplitude modulation and pure phase modulation is required for wave-front correction. So, some researchers have analysed the TN LCSLM and used different method to obtain a mostly pure phase modulation [1, 4]. Dou had used TN LCSLM in an adaptive optics system to correct the distorted wave-front [5]. Although the TN LCSLM may be used as a WFC, the twisted alignment of the liquid crystal will affect the accuracy of the adaptive correction and the resolution of the image.

In this paper, we mainly discuss the effect of the twisted alignment on the liquid crystal WFC. First, this effect is considered in terms of the principle of phase modulation of the liquid crystal. Then, the blazed grating method is proposed to eliminate the effect.

Finally, an experiment is reported that verifies our proposal and the validity of the blazed grating method.

## 2. Effect of the twisted alignment

### 2.1. Theoretical analysis

For a twisted nematic liquid crystal WFC, the principle of phase modulation is complicated to interpret. However, we just want to discuss whether it can modulate linear polarized light completely. Therefore, a simpler model is used to analyse the effect of the twisted alignment. Liquid crystal material has the properties of both a liquid and a crystal and it is a uniaxial birefringence material with a fast axis and a slow axis. The phase of the light with polarization along the slow axis will be delayed with respect to that along the fast axis. For the parallel-aligned nematic liquid crystal on silicon (LCOS) WFC shown in figure 1a, when an electric field is applied to it the liquid crystal molecule will rotate along the propagation orientation of the light and the phase delay introduced by the slow axis is reduced. Therefore, the strength of the electric field can be used to modulate the phase of the light. Assuming the linear polarized light propagates perpendicular to the glass plate and the electric field vector,  $E$ , of the light is parallel to the slow axis with an extraordinary refractive index  $n_e$ , the electric field

\*Corresponding author. Email: xuanli@ciomp.ac.cn

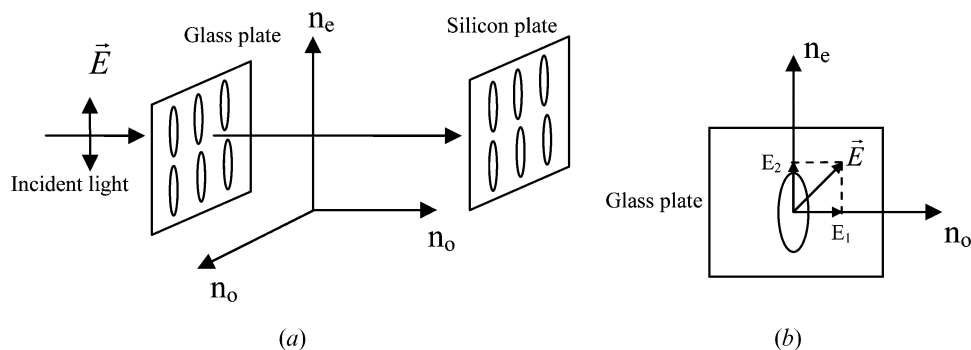

Figure 1. The structure of the parallel-aligned liquid crystal wave-front corrector (a); the electric field vector has an angle  $\theta$  with the slow axis (b).

vector,  $\mathbf{E}$ , can be modulated with different voltage. If the electric field vector,  $\mathbf{E}$ , has an angle  $\theta$  with the slow axis, as shown in figure 1b, and the incident light is still perpendicular to the glass plate, the incident electric field vector,  $\mathbf{E}$ , can be decomposed into two orthogonal electric field components  $\mathbf{E}_1$ , which is perpendicular to the slow axis and  $\mathbf{E}_2$ , which is parallel to it. Consequently, only the electric field component  $\mathbf{E}_2$  can be modulated and the driving voltage has no effect on the electric field component  $\mathbf{E}_1$ . In other words, the partial light is modulated and the residual light still has the original phase.

For the twisted nematic LCOS WFC shown in figure 2, assuming the linear polarized light propagates perpendicular to the glass plate and the electric field vector,  $\mathbf{E}$ , is parallel to the alignment of the liquid crystal molecule, the light can be completely modulated while it traverses the first layer of the liquid crystal molecule. But at the second layer, because the liquid crystal molecule is rotated, it is similar to figure 1b and the light can only be partially modulated. Similarly, other liquid crystal layers can modulate the light partially as its slow axis has an angle with the polarization direction. Consequently, if it is used to correct the wave-front, just the modulated light can be corrected and a resolvable image will be obtained. The residual still has distortions and an obscure image will be produced by it. A resolvable and obscure image will

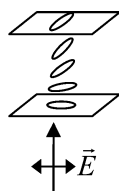

Figure 2. The twisted nematic LCOS WFC with an incident light.

be overlapped at the focal plane and the whole image will be obscure. Consequently, for a twisted nematic liquid crystal WFC, the twisted alignment will affect the resolution of the image of the optical system and correction accuracy.

## 2.2. Solution method

Because the obscure image is caused by the unmodulated light, the modulated and unmodulated light should be separated individually and only the modulated light used for the adaptive correction and imaging. One method is to use a blazed grating, which is produced by the LCOS WFC itself to separate the first-order light, which is produced with the modulated light. The unmodulated light still propagates along the original orientation and we call it zero order. Thus, just first-order light is filtered to carry out the adaptive correction, enabling high correction accuracy and a resolvable image to be obtained. The blazed grating method had been used on an ferroelectric liquid crystal (FLC) SLM to filter the first-order light by Neil *et al.* [9, 10]. As the FLC SLM just modulates the phase with 0 or  $\pi$  radian, the computer-generated holography (CGH) method is utilized to produce the continuous phase modulation. However, the diffraction efficiency of this CGH is very low and many diffractive orders appear at the Fourier plane. Because the higher diffractive orders appear close to the desired +1 order in the Fourier plane, the blazed grating is applied on the FLC SLM to separate the desired +1 order from other higher orders. For our twisted nematic liquid crystal WFC device, the CGH method does not need to be used since it can realize continuous phase modulation (see figure 3). But the unmodulated light affects the resolution of the image in an adaptive optics system. Therefore, the blazed grating method is used to separate the modulated and unmodulated light. Compared to the work of Neil *et al.* [9, 10], we just use the blazed grating method to

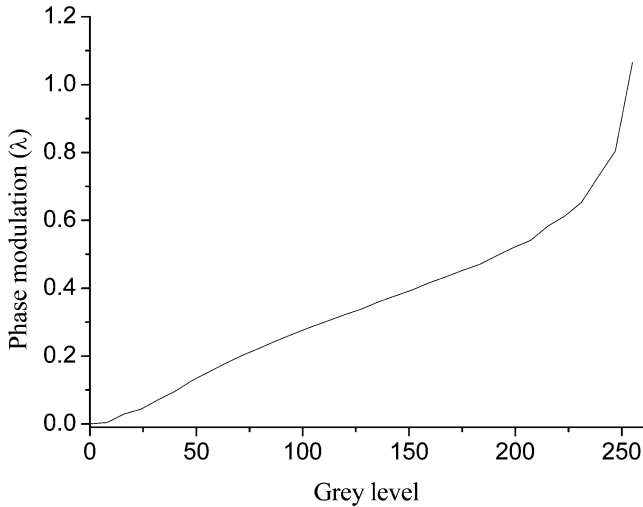

Figure 3. The phase modulation as a function of the grey level measured with a ZYGO interferometer.

eliminate the effect of twisted alignment of the liquid crystal.

### 3. Experiment

#### 3.1. Adaptive correction with zero-order light

A liquid crystal SLM (LCR-2500, Holoeye) was selected as the twisted nematic LCOS WFC; it has  $1024 \times 768$  resolution,  $75 \downarrow$  Hz frame rate and  $19.6 \times 14.5 \downarrow$  mm image dimension. The phase modulation of the twisted nematic LCOS WFC shown in figure 3 was measured with a ZYGO interferometer and the test wavelength was  $632.8 \downarrow$  nm. As it can realize  $2\pi$  radian modulation at  $632.8 \downarrow$  nm, the phase wrapping method [11] can be used to produce the large magnitude of the phase modulation with several microns. Thus, the twisted

LCOS WFC can produce an equivalent phase modulation compared to the deformable mirror.

Figure 3 shows that the phase modulation curve is nonlinear. In order to obtain a high-accuracy correction, it needs to be linearized and the gamma correction technique was used for this. The gamma correction technique is a widely used LCD technique. The video signal output from the video card does not drive the LCD panel directly, but is recoded with a so-called look-up table (LUT). Graphic adapter codes luminance values have 8 bits of resolution. With the LUT, another 9-bit code is assigned to every grey value that comes from the graphic card. It is equivalent to sampling 256 gradations from 512 grey levels and the sample rule is called the gamma correction function. A linear phase modulation curve can be achieved by adjusting the gamma correction function. The acquirement of linear phase modulation is described in detail elsewhere [12]. With the gamma correction function shown in figure 4a, a linear phase modulation curve is obtained, as shown in figure 4b.

The optical layout of an adaptive optics system is shown in figure 5. One white light source with a fibre bundle is used and the diameter of the fibre bundle is  $1 \downarrow$  mm. A polarizer is placed after the fibre bundle to produce a linear polarized light. The light emitted from the fibre bundle will be changed to parallel light by the collimation lens with a focal length of  $500 \downarrow$  mm. The light reflects from the LCOS and is then split into two beams by the beam splitter. One beam, which is filtered with a  $632.8 \downarrow$  nm narrowband coloured filter, is used to obtain the image of the fibre bundle with a camera and the other to measure the wave-front with the wave-front sensor (WFS). In order to achieve high correction accuracy, the WFS must have enough spatial resolution. A Shack–Hartman WFS fabricated by Imagine Optic

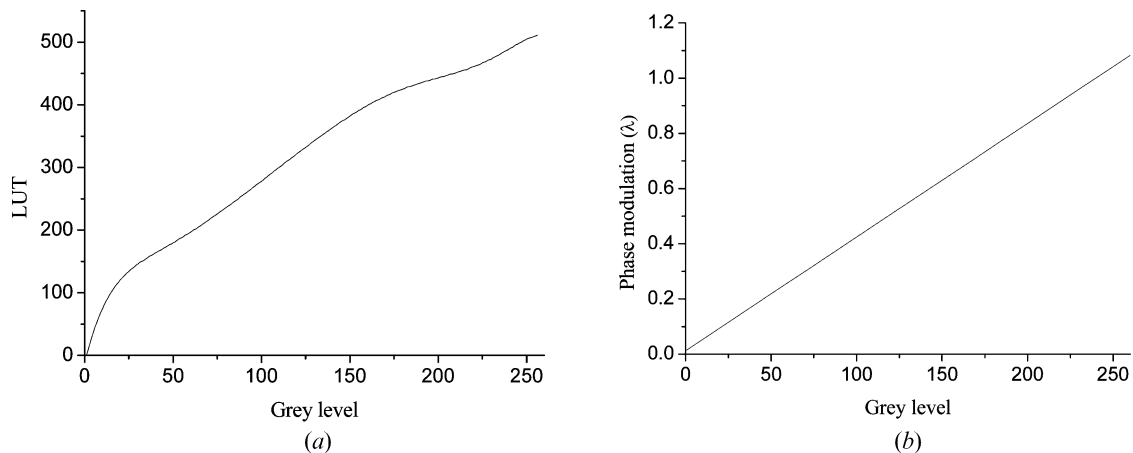

Figure 4. The linear phase modulation curve obtained with gamma correction: (a) gamma correction function; (b) linear phase modulation relation with gamma correction.

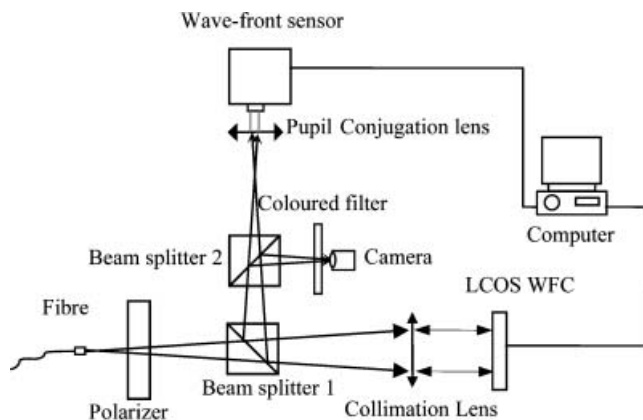

Figure 5. The optical layout of an adaptive optics system.

(HASO 32) was selected and the microlens array is  $32 \times 32$ ; its  $77 \downarrow$  Hz acquisition frequency is compatible with our LCOS device.

A computer (Pentium IV  $3.2 \downarrow$  GHz, Windows XP operating system and Imagine Optic's Wave-front Correction software) was used to control the WFS and the LCOS WFC. The WFS measures the wave-front with aberrations and sends it to the WFC. Then, the WFC produces a conjugate wave-front and transforms it to the distribution of the grey level, which is the BMP picture file obtained by using the relation curve between the phase modulation and the grey level. The picture file is sent to the driving module of the LCOS WFC through the video card. The driving module changes the picture to a voltage that corresponds to each pixel and drives the LCD panel to produce the compensated phase distribution. Thus, if the WFS detects the error of the wave-front continuously and feeds it back to the LCOS WFC, the distorted wave-front may be corrected and a resolvable image can be obtained.

Before correction, the peak to valley (PV) and root mean square (RMS) values of the distorted wave-front are  $1.74\lambda$  and  $0.39\lambda$  ( $\lambda=632.8 \downarrow$  nm), respectively (figure 6a). As the PV of the distorted wave-front is larger than  $1\lambda$ , a phase wrapping method is used to

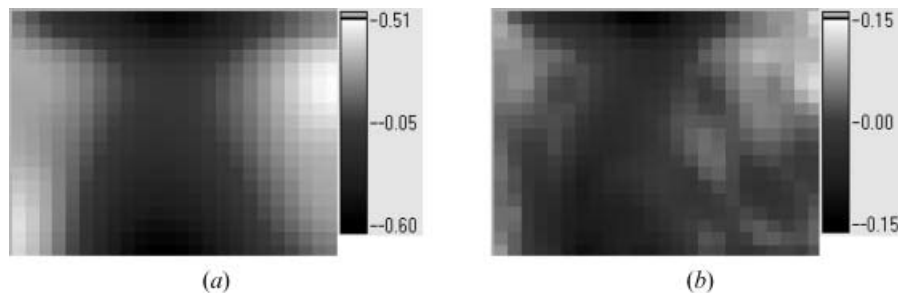

Figure 6. The phase distribution of the wave-front (in microns): (a) uncorrected; (b) corrected.

correct it. However, this method will affect the resolution of the image for white light. Hence, a  $632.8 \downarrow$  nm narrowband coloured filter is used to filter others and only the light of  $632.8 \downarrow$  nm is transmitted to the CCD camera. First 36 Zernike modes and 0.8 closed loop gain are used to correct the distorted wave-front. When the closed loop correction is completed, the PV and RMS of the averaged wave-front are  $0.43\lambda$  and  $0.079\lambda$  (figure 6b), respectively. However, the correction accuracy is poor. The images before and after correction are shown in figure 7. The image quality has almost no improvement after correction. This illustrates that the twisted alignment has an important effect on the adaptive correction.

### 3.2. Adaptive correction with the blazed grating method

A similar experiment was also performed with the blazed grating method. A  $40 \downarrow$   $\mu$ m tilt was applied to the x and y dimension of the LCOS WFC to separate the first-order light from zero order. The optical layout is shown in figure 8. It is similar to the optical setup in figure 5, but a pinhole is added before the pupil conjugation lens to filter the first-order light.

When no correction is applied, the an averaged wave-front distortion with  $PV=3.01\lambda$  and  $RMS=0.62\lambda$  is observed, as shown in figure 9a. The image is separated completely and it is obscure (figure 10a). When the

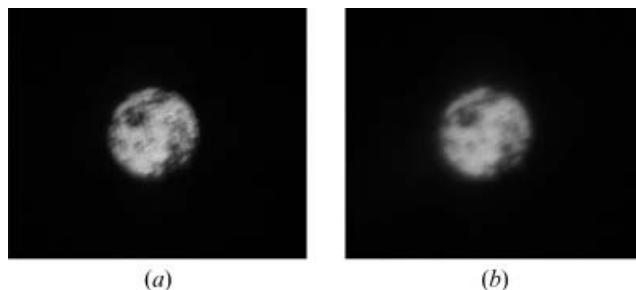

Figure 7. The image of a fibre bundle captured with the CCD camera at the image plane: (a) uncorrected image; (b) corrected image.

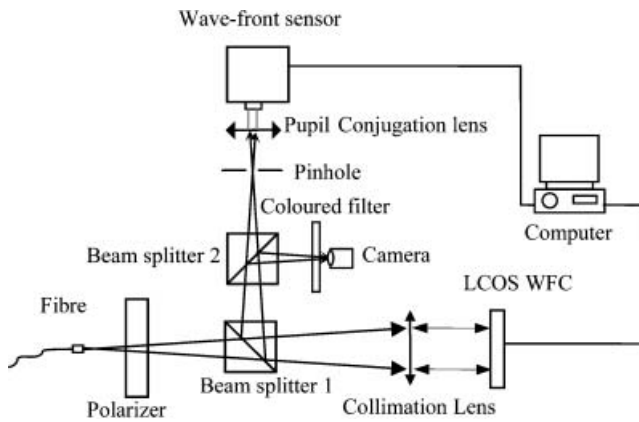

Figure 8. The optical layout of an adaptive optics system with a pinhole filter.

adaptive correction is applied the residual averaged wave-front error is  $PV=0.101\lambda$  and  $RMS=0.015\lambda$  (figure 9b). A clear image is achieved with the first-order light and each fibre core in the fibre bundle can be seen clearly (figure 10b). However, the image using zero-order light is still obscure since it can not be corrected by the liquid crystal WFC. Compared to correction without the blazed grating method, the correction accuracy is improved considerably. We have also used this method to carry out other experiments and obtained some good results [13]. This indicates that

the blazed grating method is valid and that our proposal is correct.

#### 4. Conclusions

The phase modulation characteristics of a twisted nematic LCOS WFC were investigated in terms of the phase modulation principle of the liquid crystal. Only partial incident light can be modulated because of the twisted alignment of the liquid crystal molecule. Therefore, the image is obscure and the residual wave-front error is large. A blazed grating method is proposed to solve this problem.

An adaptive optics system is established based on the Shack–Hartman wave-front sensor and the LCOS wave-front corrector. Initially, an adaptive correction was performed with zero-order light and a poor correction result was obtained. A similar experiment was performed with the blazed grating method. After adaptive correction, a clear image is obtained and a wave-front correction accuracy with  $PV=0.101\lambda$  and  $RMS=0.015\lambda$  is achieved. This illustrates that twisted alignment affects the adaptive correction and the blazed grating method can eliminate the effect of the twisted alignment. Thus, the twisted nematic liquid crystal wave-front corrector can be used in an adaptive optics system to correct the distorted wave-front and obtain good results.

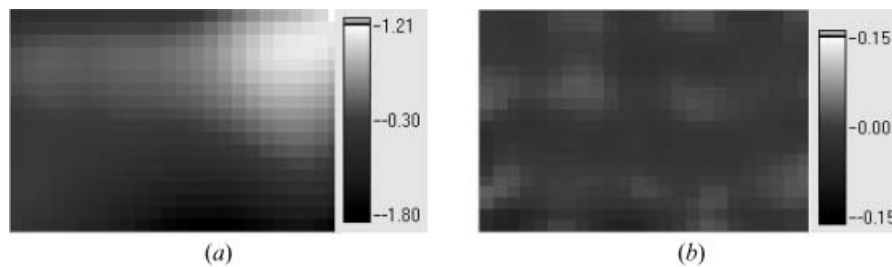

Figure 9. The wave-front measured by the wave-front sensor (the unit is wavelength): (a) uncorrected; (b) corrected.

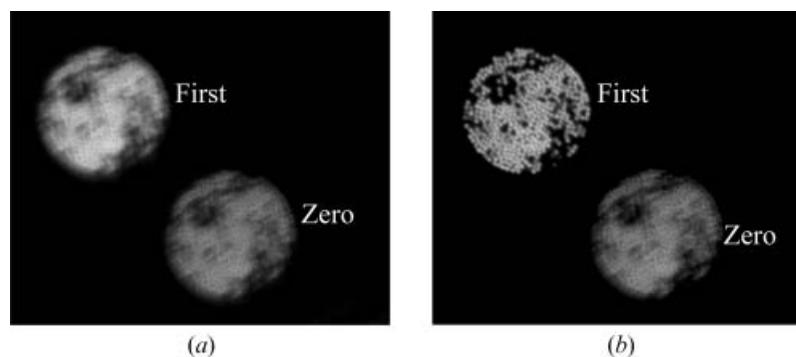

Figure 10. The image of the fibre bundle obtained with CCD camera at the focal plane: (a) uncorrected; (b) corrected.

### Acknowledgements

This work was supported by National Natural Science Foundation of China (Grant No. 50473040, 60578035) and Natural Foundation of Jilin Province (Grant No. 20050520, 20050321-2).

### References

- [1] H.T. Dai, K.S. Xu, Y.J. Liu, X. Wang, J.H. Liu. *Opt. Commun.*, **238**, 269 (2004).
- [2] M. Yamauchi, T. Eiju. *Opt. Commun.*, **115**, 19 (1995).
- [3] J.C. Kirsch, D.A. Gregory, M.W. Thie, B.K. Jones. *Opt. Engng*, **31**, 963 (1992).
- [4] T.-L. Kelly, J. Munch. *Applied Opt.*, **37**, 5184 (1998).
- [5] R. Dou, M.K. Giles. *Opt. Lett.*, **20**, 1583 (1995).
- [6] R. Dou, M.A. Vorontsov, V.P. Sivokon, M.K. Giles. *Opt. Engng*, **36**, 3327 (1997).
- [7] M.A. Vorontsov. *J. opt. Soc. America A*, **16**, 2567 (1999).
- [8] A. Márquez, M. Yamauchi, J.A. Davis, D.J. Franich. *Opt. Commun.*, **190**, 129 (2001).
- [9] M.A.A. Neil, M.J. Booth, T. Wilson. *Opt. Lett.*, **23**, 1849 (1998).
- [10] M.A.A. Neil, T. Wilson, R. Juškaitis. *J. Microsc.*, **197**, 219 (2000).
- [11] Y. Liu, Z. Cao, D. Li, Q. Mu, L. Hu, X. Lu, L. Xuan. *Opt. Engng*, **45**, 128001 (2006).
- [12] Z. Cao, Q. Mu, L. Hu, Y. Liu, Z. Peng, L. Xuan, *Chin. Phys. Lett.* (submitted).
- [13] Q. Mu, Z. Cao, L. Hu, D. Li, L. Xuan. *Opt. Express*, **14**, 8013 (2006).